

grip 工業機器人周邊部件



EXCHANGE

工業機器人手動快速換模系統

MGW
SHW
SWA
SWS

手動
換模
系列

Gi
GiS
GP
GZ

Internal
Gripper
&
Gripper

DDF
MEK
SEK

Swivel
&
Energy
Coupling



MGW 手動氣壓夾爪快速換模系統 Manual Gripper Changing System

- 規格：6種
- 不需要工具就可拆和裝
- 承受低重量的高負載
- 5,000次更換週期壽命
- 符合DIN EN ISO 9409-1的連接端面
- 最高承受荷重：10 ~ 120Kg

03~09頁



SHW 推力槓桿換模系統 Thrust Lever-Changing System

- 規格：5種
- 承受低重量的高負載
- 重複精度：±0.02mm
- 50,000次更換週期壽命
- 符合DIN EN ISO 9409-1的連接端面
- 最高承受荷重：12 ~ 75Kg
- 不需要工具就可拆和裝

10~15頁



SWA 快速換模連接系統 Quick-Change-Adapter

- 規格：6種
- 重複精度：±0.02mm
- 承受低重量的高負載
- 50,000次更換週期壽命
- 符合DIN EN ISO 9409-1的連接端面
- 最高承受荷重：8 ~ 62Kg

16~22頁



SWS 快速換模系統 Quick-Change-System

- 規格：9種
- 重複精度：±0.02mm
- 承受低重量的高負載
- 50,000次更換週期壽命
- 符合DIN EN ISO 9409-1的連接端面
- 最高承受荷重：14 ~ 200Kg

24~33頁

氣壓內孔夾具 Internal Gripper & 氣壓夾爪 Gripper

Gi 內孔夾持器
4~20mm



GiS 內孔夾持器
5~20mm



GP 氣壓平行夾爪



GZ 氣壓夾爪
Y型(60度)



氣壓旋轉接頭 Multiport Swivel & 氣和電信號-快速連接 Multi-Energy-Coupling 標準化產品

DDF 空氣4通道
旋轉接頭



MEK 氣/電
快速連接器



SEK 氣/電
快速連接器



◎ 目錄上所有的功能尺寸及公差僅供參考，本公司保有變更之權力並不事先通知。◎ 請有任何疑問及特殊需求請洽詢本公司。

SHW 推力槓桿 快速換模 系列

MGW050
MGW063
MGW080
MGW100
MGW125
MGW160



操作模式：推力螺栓無間隙地以閉合方式支撐上部件和下部件，不需要工具就可拆和裝

優點：

- 規格：5種
- 重複精度：±0.02mm
- 由高強度鋁製成，重量輕，陽極氧化
- 鎖定銷可防止手柄鬆脫
- 彈性鎖定銷將手柄固定在獨立釋放位置
- 最高承受荷重：12 ~ 75Kg
- 承受低重量的高負載
- 50,000次更換週期壽命
- 符合DIN EN ISO 9409-1的連接端面
- 可根據客戶的要求設計

SHW 拆/裝方式和步驟



SHW063 推力槓桿換模系統

Thrust Lever-Changing System

SHW
推力槓桿
快速換模
系列

SHW063

- SHW080
- SHW100
- SHW125
- SHW160

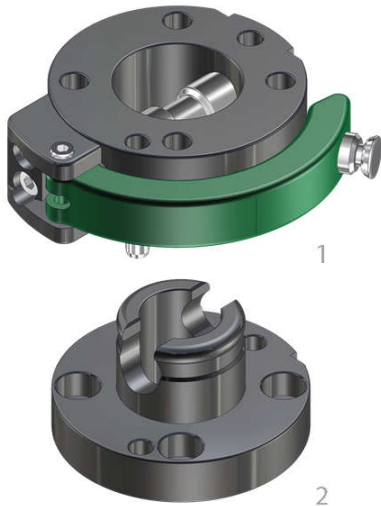

Operating mode:
By operating the hand lever on the upper part (1), the crossway bolt is displaced radially. The crossway bolt is pressed into the bore of the lower part (2).

Advantages:
Withstands high loads with low dead weight
Intuitive operation
Can be released and closed with one handle
High repeatability +/- 0.02 mm
Holds up to 5.000 changing cycles
Optional connection of a power coupling SEK for electrical ducts
Interface according to DIN EN ISO 9409-1

Technical specifications		SHW063
Basic material		Al. anod.
External diameter x height [mm]		63 x 32
Pitch circle diameter [mm]		50
Repeatability +/- [mm]		0,02
Tension Fz [N]		700
Compression -Fz [kN]		80
Torsion Mz [Nm]		80
Bend Mx, My [Nm]		70
Mass [kg]	upper part	0,25
	lower part	0,1
Recommended load [kg]		12
Locking force VF [N]		4 - 50
Locking stroke VH [mm]		0 - 1

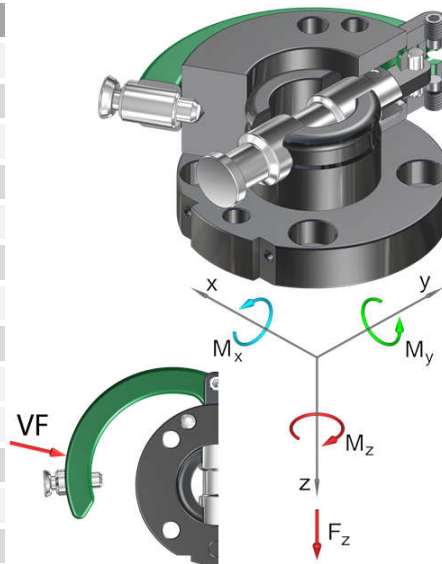

Pos.	Description
1	Upper part
2	Crossway bolt
3	Hand lever
4	Holder
5	Strap pin
6	Spring locking pin
7	Guiding screw
8	Index pin
9	Cylinder bolt BL
10	Cylinder bolt QB
11	Shim ring
12	Lower part

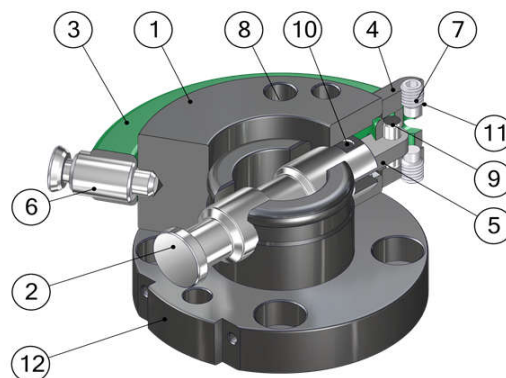

Thrust Lever-Changing System Ø63...	
G-SHW063-2OE	drilled acc. to ISO, upper part, E-Mount, Al, anodized
G-SHW063-2UE	drilled acc. to ISO, lower part, E-Mount, Al, anodized

SHW 推力槓桿 快速換模 系列

SHW063

SHW080

SHW100

SHW125

SHW160

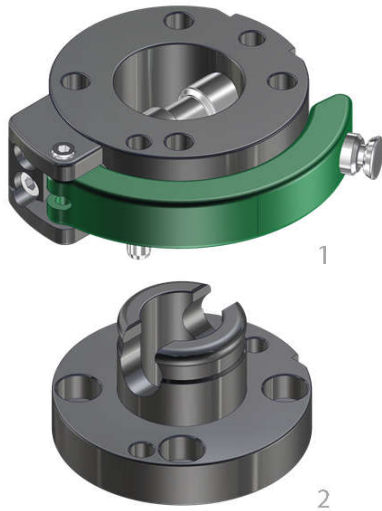

Operating mode:

By operating the hand lever on the upper part (1), the crossway bolt is displaced radially. The crossway bolt is pressed into the bore of the lower part (2).

Advantages:

Withstands high loads with low dead weight

Intuitive operation

Can be released and closed with one handle

High repeatability +/- 0.02 mm

Holds up to 5.000 changing cycles

Optional connection of a power coupling SEK for electrical ducts

Interface according to DIN EN ISO 9409-1

Technical specifications		SHW080
Basic material		Al. anod.
External diameter x height [mm]		80 x 37
Pitch circle diameter [mm]		63
Repeatability +/- [mm]		0,02
Tension Fz [N]		800
Compression -Fz [kN]		160
Torsion Mz [Nm]		100
Bend Mx, My [Nm]		100
Mass [kg]	upper part	0,41
	lower part	0,2
Recommended load [kg]		16
Locking force VF [N]		5 - 60
Locking stroke VH [mm]		0 - 1

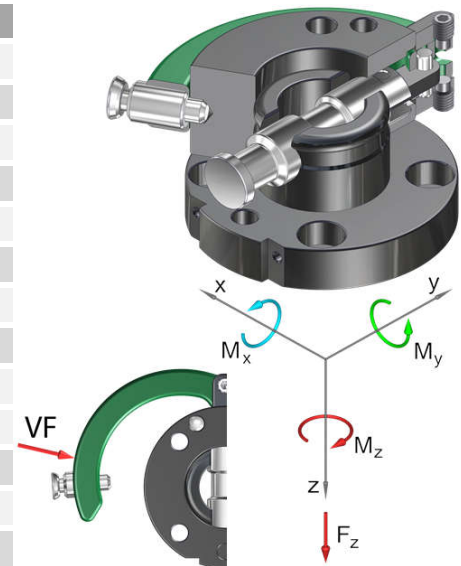

Pos.	Description
1	Upper part
2	Crossway bolt
3	Hand lever
4	Holder
5	Strap pin
6	Spring locking pin
7	Guiding screw
8	Index pin
9	Cylinder bolt BL
10	Cylinder bolt QB
11	Shim ring
12	Lower part

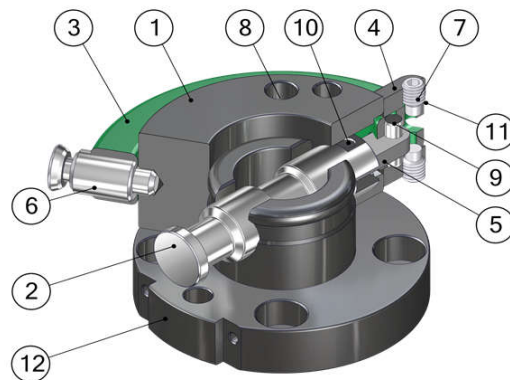

Thrust Lever-Changing System Ø63...

G-SHW080-2OE drilled acc. to ISO, upper part, E-Mount, Al, anodized

G-SHW080-2UE drilled acc. to ISO, lower part, E-Mount, Al, anodized

© 目錄上所有的功能尺寸及公差僅供參考，本公司保有變更之權力並不事先通知。◎ 請有任何疑問與特殊需求請洽詢本公司。

SHW100 推力槓桿換模系統

Thrust Lever-Changing System



SHW 推力槓桿 快速換模 系列

SHW063
SHW080
SHW100
SHW125
SHW160

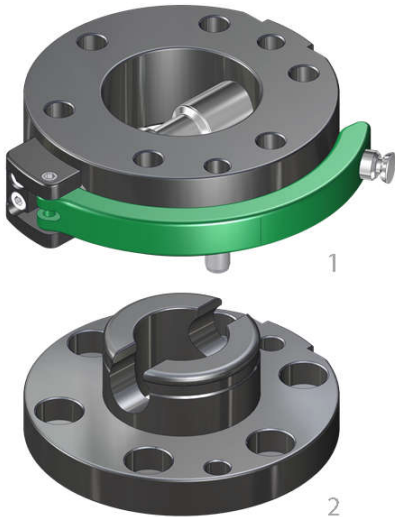

Operating mode:
By operating the hand lever on the upper part (1), the crossway bolt is displaced radially. The crossway bolt is pressed into the bore of the lower part (2).

Advantages:
Withstands high loads with low dead weight
Intuitive operation
Can be released and closed with one handle
High repeatability +/- 0.02 mm
Holds up to 5.000 changing cycles
Optional connection of a power coupling SEK for electrical ducts
Interface according to DIN EN ISO 9409-1

Technical specifications		SHW100
Basic material		Al. anod.
External diameter x height [mm]		100 x 45
Pitch circle diameter [mm]		80
Repeatability +/- [mm]		0,02
Tension Fz [N]		1.000
Compression -Fz [kN]		219
Torsion Mz [Nm]		140
Bend Mx, My [Nm]		130
Mass [kg]	upper part	0,74
	lower part	0,35
Recommended load [kg]		24
Locking force VF [N]		6 - 70
Locking stroke VH [mm]		0 - 1

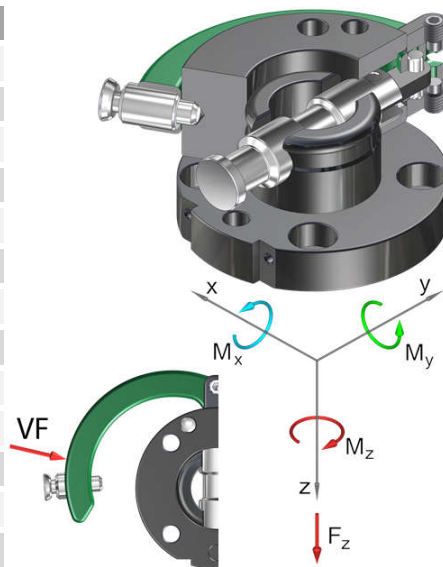

Pos.	Description
1	Upper part
2	Crossway bolt
3	Hand lever
4	Holder
5	Strap pin
6	Spring locking pin
7	Guiding screw
8	Index pin
9	Cylinder bolt BL
10	Cylinder bolt QB
11	Shim ring
12	Lower part

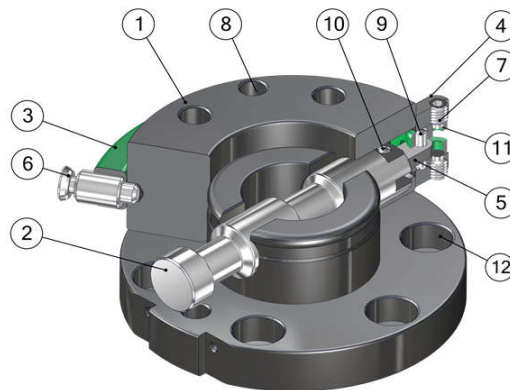

Thrust Lever-Changing System Ø63...	
G-SHW100-20E	drilled acc. to ISO, upper part, E-Mount, Al, anodized
G-SHW100-2UE	drilled acc. to ISO, lower part, E-Mount, Al, anodized

SHW 推力槓桿 快速換模 系列

SHW063

SHW080

SHW100

SHW125

SHW160

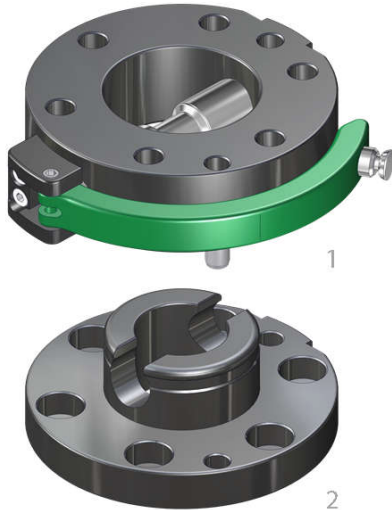

Operating mode:

By operating the hand lever on the upper part (1), the crossway bolt is displaced radially. The crossway bolt is pressed into the bore of the lower part (2).

Advantages:

Withstands high loads with low dead weight

Intuitive operation

Can be released and closed with one handle

High repeatability +/- 0.02 mm

Holds up to 5.000 changing cycles

Optional connection of a power coupling SEK for electrical ducts

Interface according to DIN EN ISO 9409-1

Technical specifications		SHW125
Basic material		Al. anod.
External diameter x height [mm]		125 x 50
Pitch circle diameter [mm]		100
Repeatability +/- [mm]		0,02
Tension Fz [N]		1.200
Compression -Fz [kN]		377
Torsion Mz [Nm]		180
Bend Mx, My [Nm]		180
Mass [kg]	upper part	1,3
	lower part	0,55
Recommended load [kg]		35
Locking force VF [N]		8 - 80
Locking stroke VH [mm]		0 - 1

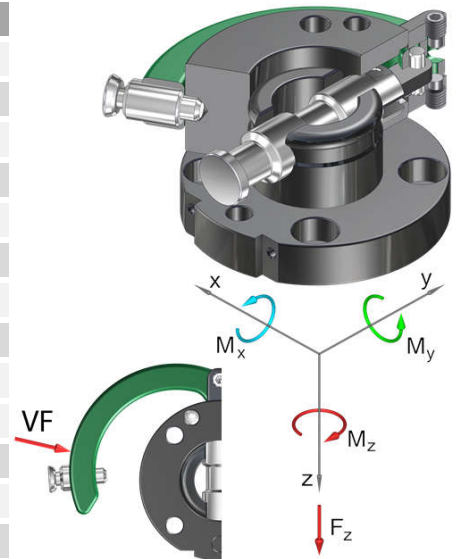

Pos.	Description
1	Upper part
2	Crossway bolt
3	Hand lever
4	Holder
5	Strap pin
6	Spring locking pin
7	Guiding screw
8	Index pin
9	Cylinder bolt BL
10	Cylinder bolt QB
11	Shim ring
12	Lower part

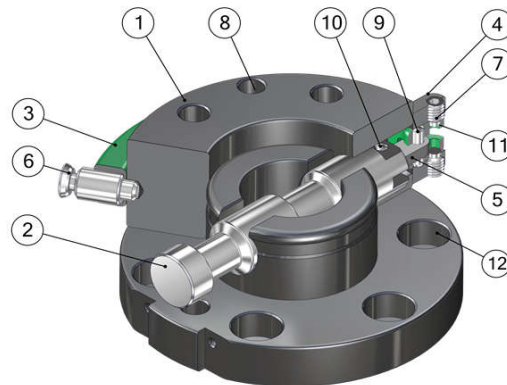

Thrust Lever-Changing System Ø63...

G-SHW125-20E	drilled acc. to ISO, upper part, E-Mount, Al, anodized
G-SHW125-2UE	drilled acc. to ISO, lower part, E-Mount, Al, anodized

© 目錄上所有的功能尺寸及公差僅供參考，本公司保有變更之權力並不事先通知。◎ 請有任何疑問與特殊需求請洽詢本公司。

SHW160 推力槓桿換模系統

Thrust Lever-Changing System



SHW 推力槓桿 快速換模 系列

SHW063
SHW080
SHW100
SHW125

SHW160

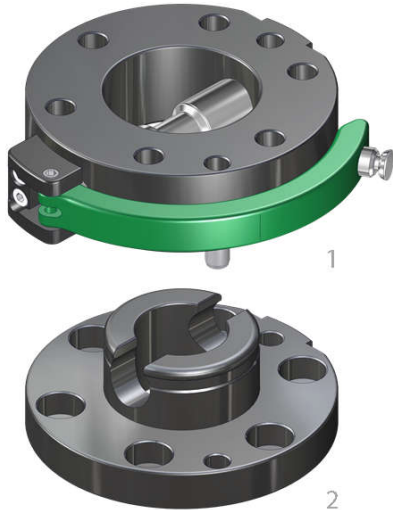

Operating mode:

By operating the hand lever on the upper part (1), the crossway bolt is displaced radially. The crossway bolt is pressed into the bore of the lower part (2).

Advantages:

Withstands high loads with low dead weight

Intuitive operation

Can be released and closed with one handle

High repeatability +/- 0.02 mm

Holds up to 5.000 changing cycles

Optional connection of a power coupling SEK for electrical ducts

Interface according to DIN EN ISO 9409-1

Technical specifications		SHW160
Basic material		Al. anod.
External diameter x height [mm]		160 x 70
Pitch circle diameter [mm]		125
Repeatability +/- [mm]		0,02
Tension Fz [N]		2.000
Compression -Fz [kN]		626
Torsion Mz [Nm]		300
Bend Mx, My [Nm]		320
Mass [kg]	upper part	2,8
	lower part	1,2
Recommended load [kg]		75
Locking force VF [N]		10 - 100
Locking stroke VH [mm]		0 - 1

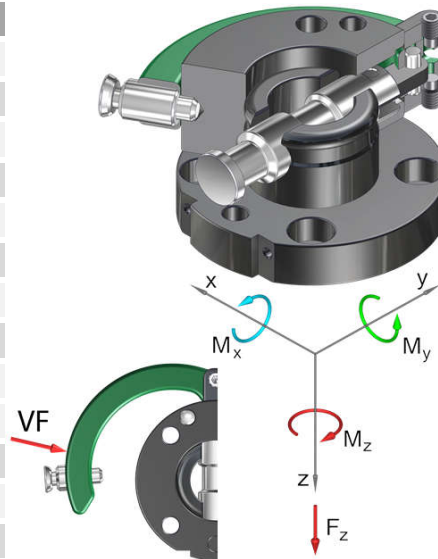

Pos.	Description
1	Upper part
2	Crossway bolt
3	Hand lever
4	Holder
5	Strap pin
6	Spring locking pin
7	Guiding screw
8	Index pin
9	Cylinder bolt BL
10	Cylinder bolt QB
11	Shim ring
12	Lower part

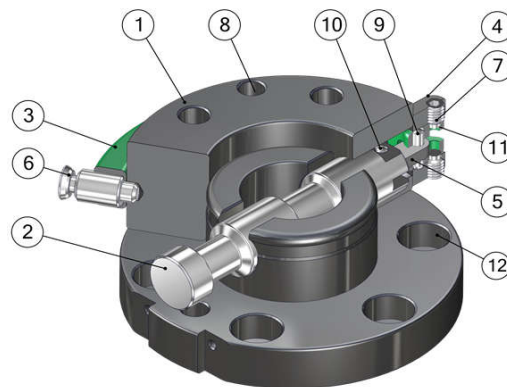

Thrust Lever-Changing System Ø63...

G-SHW160-2OE	drilled acc. to ISO, upper part, E-Mount, Al, anodized
G-SHW160-2UE	drilled acc. to ISO, lower part, E-Mount, Al, anodized